

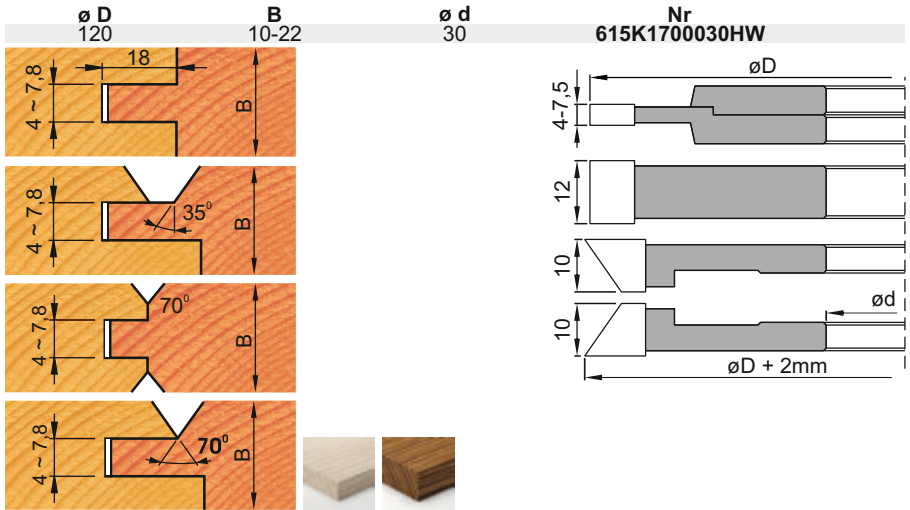

**170 HOBY PERO-DRÁŽKA FRÉZY HW**

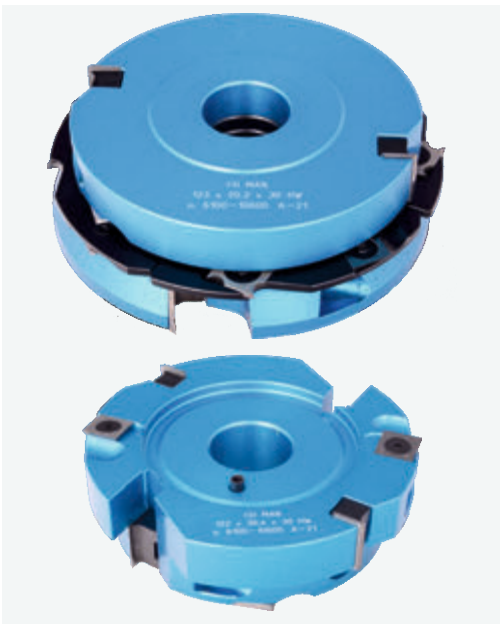

Remeselná sada fréz pre štyri druhy profilov pero-drážky.



**YS113AZM PERO-DRÁŽKA LIGHT HW**

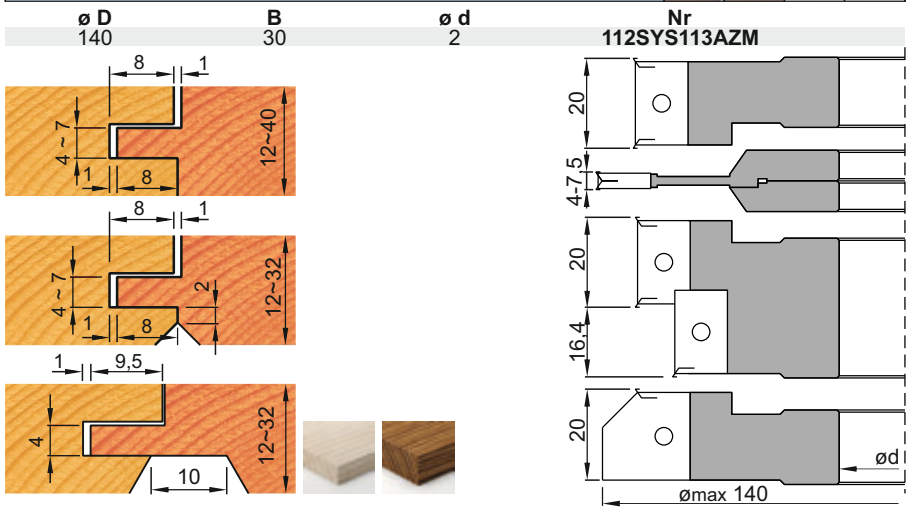

Sada pozostávajúca zo 4 nástrojov, kombináciou ktorých je možné dosiahnuť 3 typy profilov. Nástroje sú určené pre spodné frézovačky a sú vhodné aj pre ručný posuv.

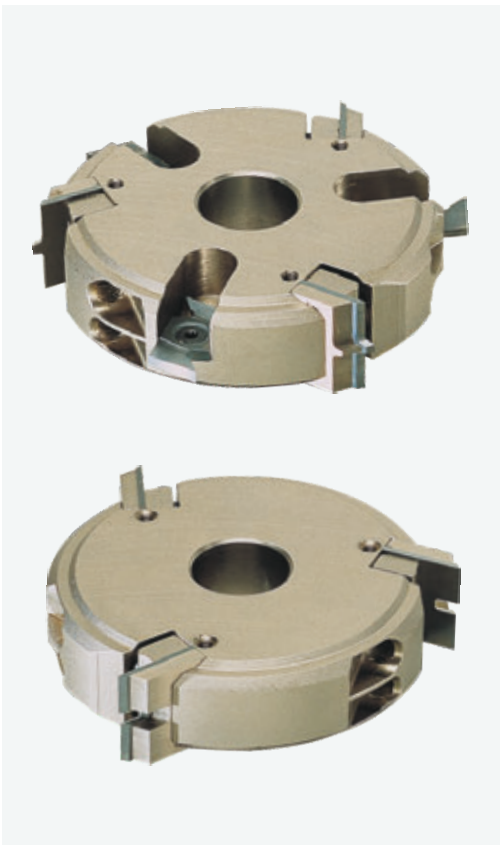

**425 PERO-DRÁŽKA MULTI HW**

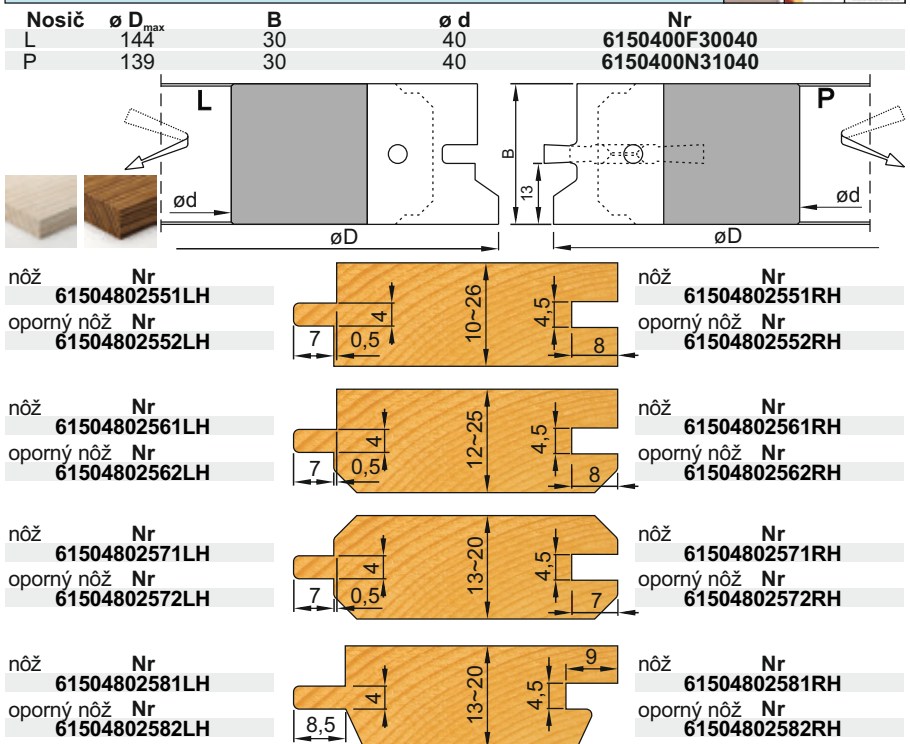

Univerzálny systém fréz pre profily typu pero-drážka. Nosiče sa osádzajú vybraným typom nôžov.

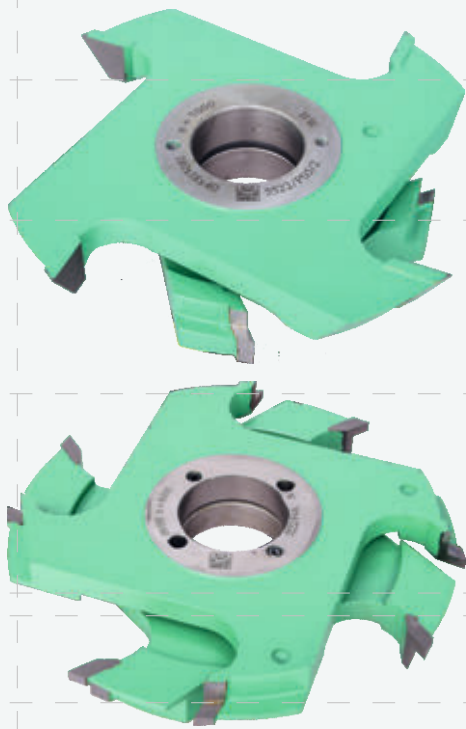

### 5022 PERO-DRÁŽKA FRÉZY

HW



TYP	ø D	B	ø d	Z	Nr SET
1	160	12-50	40	4	1115522P2D1
3	135	13-28	40	4	1115021P3D3
3	179	13-28	40	4	1115022P3D3
5	135	13-35	40	4	1115021P5D5
5	180	13-35	40	4	1115522P5D5
8	172	13-32	40	4	1115022P8D8

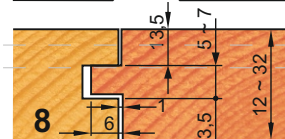
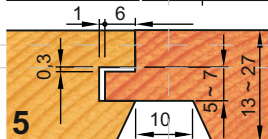
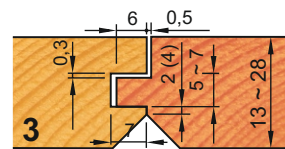
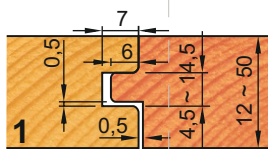
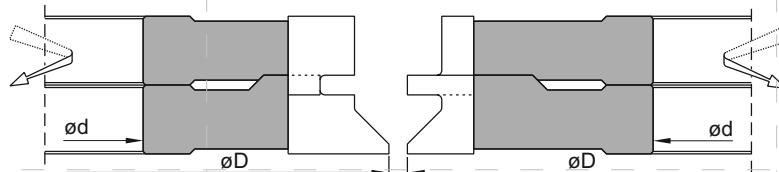

Štandardné sady produkčných nástrojov do štvorstranných frézovačiek. Na zákazku dodávame sady podľa konkrétneho zadania.

### T330 PERO-DRÁŽKA INDUSTRY

HW



Fréza č.	ø D	B	ø d	Z	Nr
1	160	20	40	4	235T330M16020AA
2	147	12	40	4	235T330M14712AA
3	159	20	40	4	235T330M15920AA
4	175	25	40	4	235T330M17525AA
5	175	25	40	4	235T330M17525BA
6	174	12	40	4	235T330M17412AA
7	174	12	40	4	235T330M17412BA
8	160	20	40	4	235T330M16020BA
9	195	15	40	4	235T330M19515AA
10	175	15	40	4	235T330M17515AA
11	169	20	40	4	235T330M16920AA
12	184	25	40	4	235T330M18425AA
13	184	18,5	40	4	235T330M18418AA

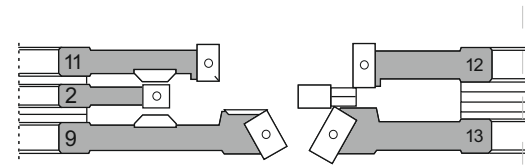
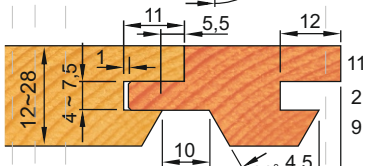
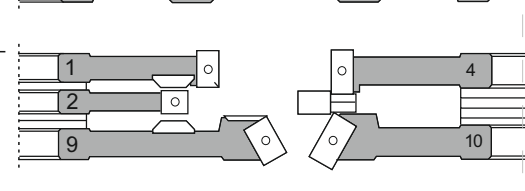
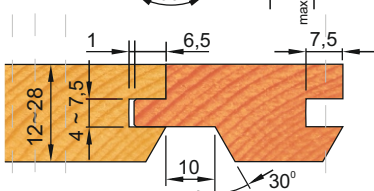
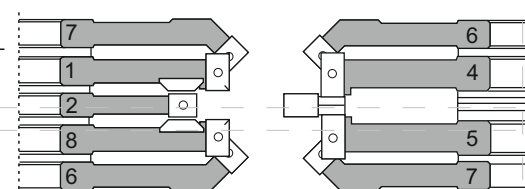
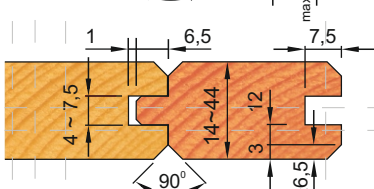
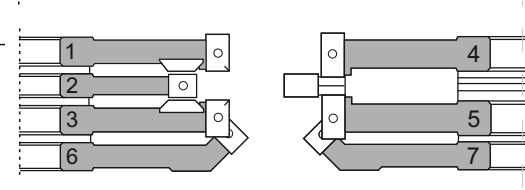
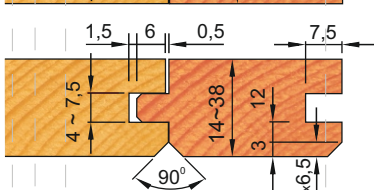
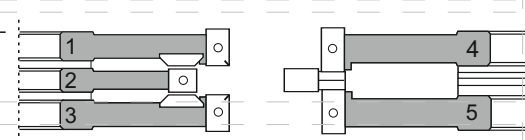
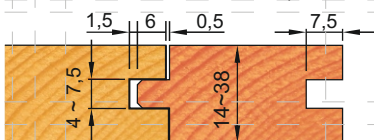
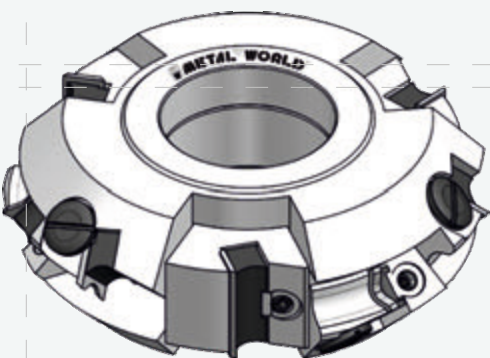
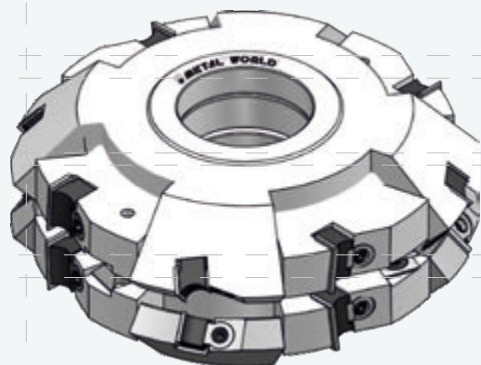

Priemyselný frézovací systém pre pero-drážkové konštrukcie. Nástroje sú osadené štandardnými žiletkami pre čo najmenšie náklady na bežný meter opracovania. Zostavením rôznych kombinácií nástrojov je možné doceliť široké spektrum profilov.