

# GL207M

# Dado set

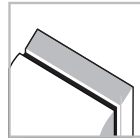

Manual Feed



Brazed Cutter



Steel Body



Softwood



Hardwood



Chipboard



Laminated chipboard



MDF



Laminated MDF

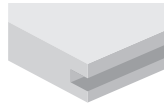

Grooving

D mm	B-B1 mm	d mm	Z	Max RPM 1/min.	Freud Code	Art. No.
207,1	6-22	30	34	8.500	GL20701M	F03FS09237



**Machines:**  
Spindle moulders and manual feed machines.

**Materials:**  
Softwood, hardwood and wood composites.

**Applications:**  
Grooving.

**Technical information:**  
Tool set including 2 blades, 5 chippers and a spacers set for grooving thickness fine adjustment (Fig. 1).  
• Steel body.

With 16 different combinations of the elements, it is possible to obtain a range of grooving thicknesses from 6 mm to 22 mm (7 mm excluded).  
The matching pins in the set elements are preventing their mutual rotation (Fig. 2).

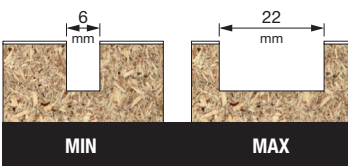
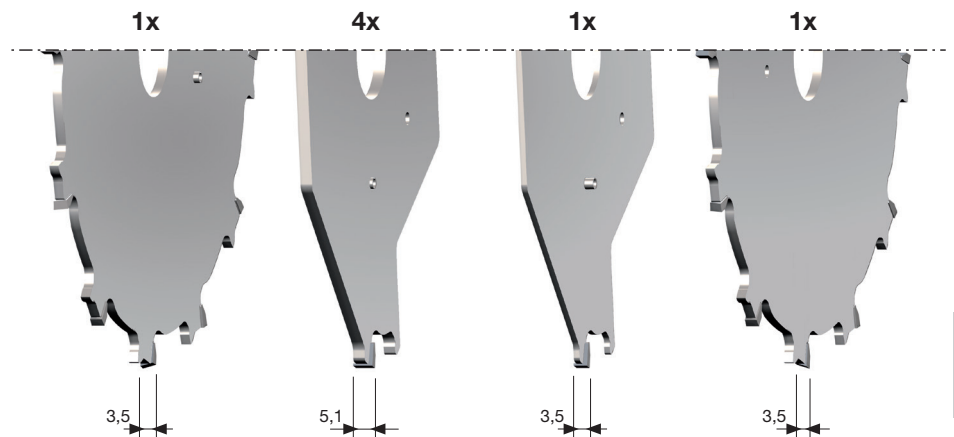

Fig. 1

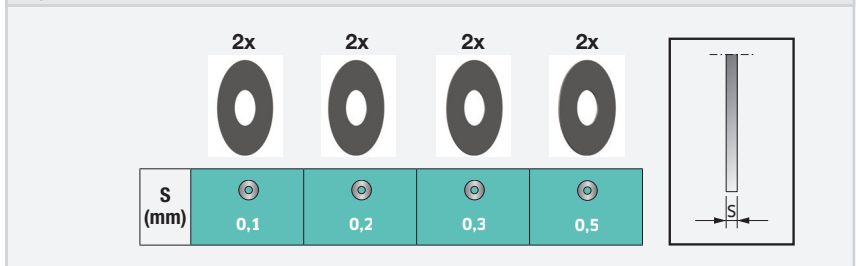

Fig. 2

