

minimax *line*

elite range



All “Made in SCM Italy”

From casting iron to finished product.

Come see our production plants and touch the quality of SCM machines;
you will be our guest.



minimax

the passion that deserves professional products.

minimax is the line of professional machines for hobbyists and woodworkers, a point of reference for over 40 years worldwide.

SCM's objective is to guarantee customers high quality technologies which meet their requirements in such a way as to make SCM the partner for any needs.

elite

Solid, flexible and economical.

combined machines

cu 410e
page 6



fs 41e
page 7



st 4e
page 8



circular saw

sc 4e
page 9





App Thundercut

Technology at your fingertips

SCM Thundercut is the Optimizer/Sequencer App for mobile devices, that allows to optimize the panel surface and guides the operator through the cutting sequence.

High cut speed execution, less material waste and mistake odds minimized, even for not skilled workers!

Download it now from the AppStore and Google Play:

SCM Thundercut



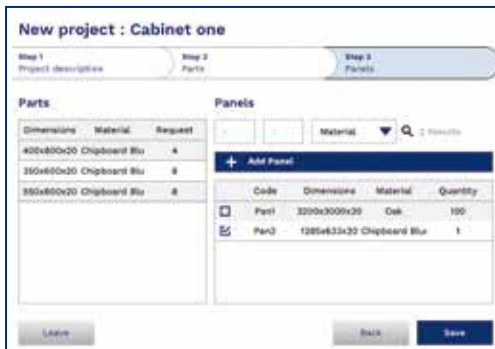
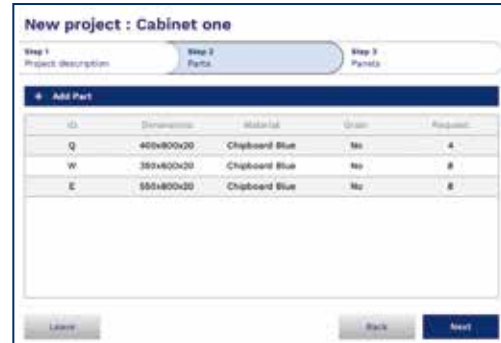
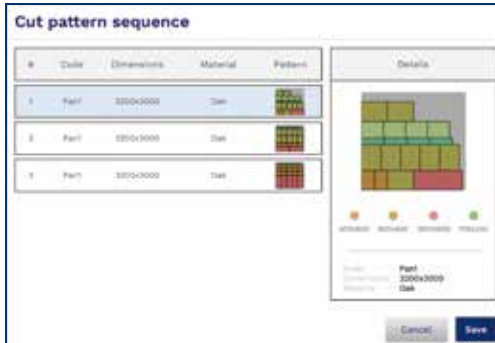

You can manage your circular saws fleet, the material warehouse and many project you are working on.

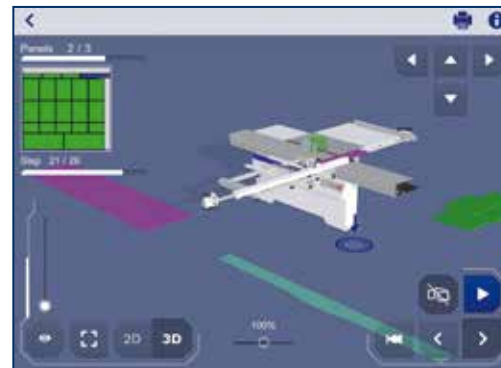

The 3D sequencer, thanks to its simple and clear design, suggest the ideal settings of the machine for every single cut to be executed.

The App is available for circular saws, circular saws with movable blade unit, saw-shaper combination machines and universal combination machines (you will find the QR code to activate the App in each new machine).

elite
combined machines
cu 410e
fs 41e

universal combined machine
surfacing-thicknessing planer



		cu 410e	fs 41e
Planer useful working width	mm	410	410
Total length of surfacing tables	mm	2000	2000
Max. saw blade diameter with scoring blade installed	mm	3 ÷ 240	3 ÷ 240
Squaring stroke	mm	315	-
Max. spindle length	mm	125	-
Three-phase motors starting from	kW/Hz	4 (4,8) / 50 (60)	4 (4,8) / 50 (60)

Find the complete technical specification at page 14

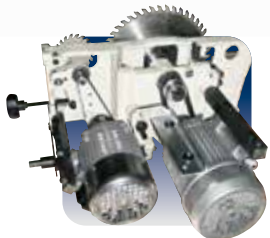

Saw Unit
stability and rigidity



Planer Cutter Block
perfect finishing



Spindle Moulder
versatility



Digital Readout
hi-tech devices



Sliding Table
precise and silent



SCM
Thundercut
Optimizer/
Sequencer App

Solid, flexible and affordable machines for woodworking shops and demanding craftsmen that want to achieve a qualitatively superior finished product.

combined machine and circular saw

elite
 st 4e saw-spindle moulder
 sc 4e circular saw



		st 4e	sc 4e
Max. saw blade diameter with scoring blade installed	mm	315	315
Squaring stroke	mm	1600 ÷ 3200	2250 ÷ 3200
Max. useful spindle length	mm	125	-
Three-phase motors starting from	kW/Hz	4 (4,8) / 50 (60)	4 (4,8) / 50 (60)

Find the complete technical specification at page 14

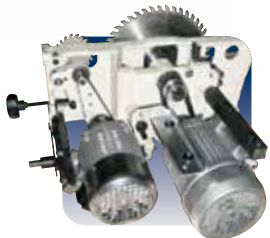

Saw Unit
stability and rigidity



Spindle Moulder
versatility

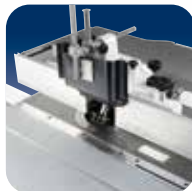

Moulder Guide
hi-tech devices



Digital Readout
hi-tech devices



Sliding Table
precise and silent



SCM
Thundercut
Optimizer/
Sequencer App

elite operating groups



The lifting of the blade unit is done by a robust cast iron structure with dovetail system.



The rotation fulcrums of the saw unit have a 120 mm diameter and stand on steady crescent shaped rests that separate it from the base: a rigid reliable solution.



90° ÷ 45°

stability and rigidity

Saw Unit.

The new **saw unit closed loop structure is made of a heavy cast iron** and is supported firmly under the table by two lateral supports in a crescent shape. These solutions give strength and rigidity, guaranteeing perfect cutting results. The saw unit can be equipped, on request, with scoring blade for perfect cutting even on veneered panels. The scoring blade is an option available in two versions: with belt transmission from the main motor and with an independent motor 0.75 HP (0.55 kW). The maximum diameter allowed for the main saw is **315 mm with scoring blade mounted**.

The scoring blade is adjustable from the outside without tools and allows fast and accurate positioning with no play.





precise and silent

Sliding Table.

Optimal support also to larger pieces, with the **sliding table 360 mm wide**. Exceptional precision and smoothness: to secure the guides it is not used glue, since the thickness could affect sliding. They are secured with a procedure of aluminum riveting.

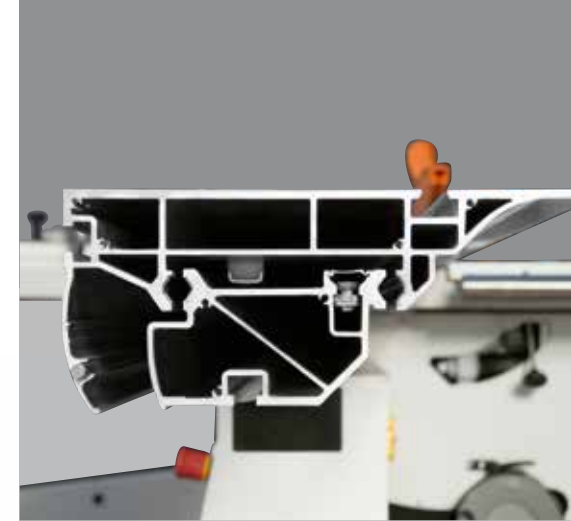

high-tech devices

Digital Readout.

The round cross-section sliding bar for the parallel fence (optional device for **cu 410e**) with micrometric adjustments ensures a smooth, fast and especially precise positioning of the fence. The support of the fence can also be equipped with a **digital readout**, with the sensor running on a magnetic stripe (option).

Panel loading is easy on the **large squaring frame** with an idle roller at the end. The **telescopic squaring fence with two reversible stops** can be used to square panels measuring 3200 x 3200 mm and for miter cuts at up to 45° on both sides of the frame.

elite operating groups



perfect finishing

Planer Cutter Block.

The planer unit stands on cast iron supports and the standard version has a 87 mm diameter cutter block with 3 knives. (The optional "Tersa" cutter block is available with 4 quick tightening knives and automatic adjustment).

For an impeccable finish, the pressure of the thicknesser feed rollers can be adjusted according to the type of wood machined.

The infeed roller (A) has a **helicoidal profile** to guarantee firm and constant work piece feed, while the outfeed roller (B), in sandblasted steel, maintains the perfect post-processing finishing.



A

B

Two feed speed for the standard thicknesser (6 - 12 m/min.). In the **cu 410e** the planers open towards the circular saw-spindle moulder side: an ergonomic solution with minimum amount of space.



The **fs 41e** uses a dedicated planing fence extremely rigid and smooth, thanks to a support with central round bar.



functional and customisable

A machine even more versatile: with the practical **mortiser** (option) drilling holes or mortises are easily done.



versatility

Spindle Moulder.

Maximum stability and rigidity in all working conditions, thanks to a large spindle moulder column made entirely of cast iron.

The 4 standard speeds are ideal for any type of machining, from moulding to routing and tenoning with the possibility to fit tools up to 275 mm of diameter. The spindle is surrounded by a cast iron "cup" to protect the internal mechanical components from shavings and sawdust.



high-tech devices

Moulder Fence.

The standard spindle moulder hood (A) can house tools of maximum diameter 210 mm. Available as an option, the spindle moulder hood that uses an adjustment system of the guides through rack and it has a mechanical digital readout (B). Thanks to the **memories system**, this hood can be removed and replaced without losing the operating position.

The maximum capacity of the tool used in profiling is 240 mm in diameter. It is available, on request, the tilting spindle 45° towards the inside machine.



A

B

elite dimensions and technical data

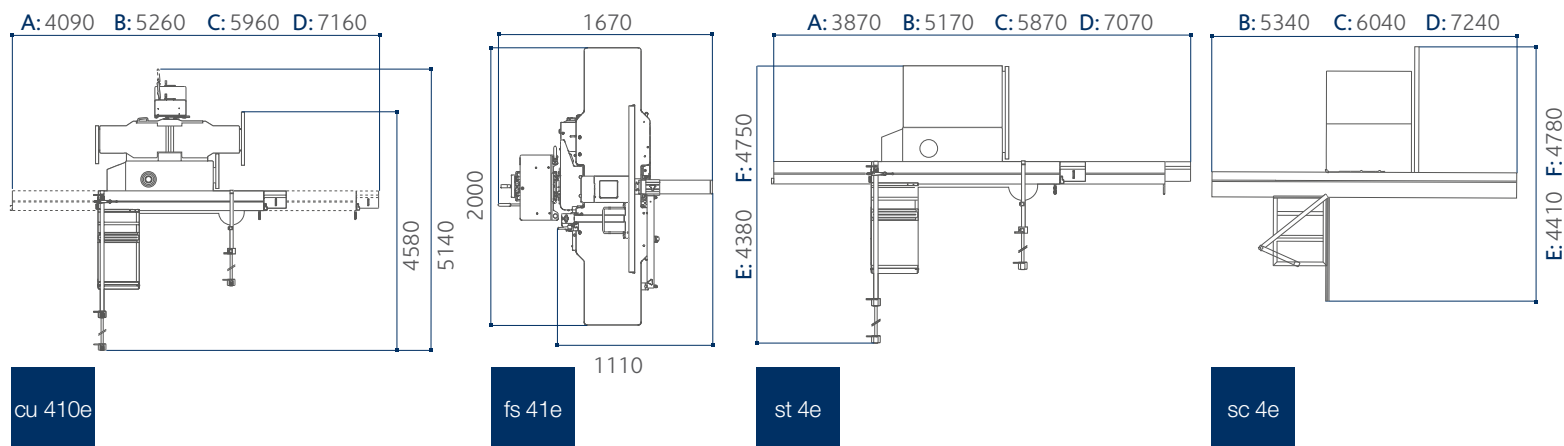

S Standard
O Option

		cu 410e	fs 41e	st 4e	sc 4e
planer					
Working width	mm	410	410	-	-
Cutter block diameter (mm)/no. of standard knives	mm/n.	87 / 3	87 / 3	-	-
Dimensions of standard knives	mm	410 x 30 x 3	410 x 30 x 3	-	-
Max. stock removal	mm	5	5	-	-
Surfacing tables total length	mm	2000	2000	-	-
Thickening table dimensions	mm	423 x 775	423 x 775	-	-
Feed speed on thickener	m/min	6 / 12	6 / 12	-	-
Min. ÷ max. working height on thickener	mm	3 ÷ 230	3 ÷ 230	-	-
circular saw					
Cast iron saw-spindle moulder worktable dimensions	mm	1250 x 430	-	1250 x 430	840 x 560
Saw blade tilting		90° ÷ 45°	-	90° ÷ 45°	90° ÷ 45°
Max. saw blade diameter with scoring blade installed	mm	315	-	315	315
Max. saw blade projection from table at 90°/45°	mm	100 / 70	-	100 / 70	100 / 70
Squaring stroke	mm	1600 ÷ 3200	-	1600 ÷ 3200	2250 ÷ 3200
Cutting width on parallel fence	mm	1050	-	900 ÷ 1270	900 ÷ 1270
spindle moulder					
Max. useful spindle length	mm	125	-	125	-
Spindle moulder speeds (at 50 Hz)	rpm	3500 / 6000 / 8000 / 10.000	-	3500 / 6000 / 8000 / 10.000	-
Max. tool diameter when profiling	mm	210 ÷ 240	-	210 ÷ 240	-
Max. diameter of tool lowered under the table at 90°	mm	240	-	240	-
Max. tool diameter when tenoning	mm	275	-	275	-
other technical features					
Three-phase motors 4 kW (5,5 hp) 50 Hz - 4,8 kW (6,5 hp) 60 Hz		S	S	S	S
Three-phase motors 5 kW (6,6 hp) 50 Hz - 6 kW (8 hp) 60 Hz		O	O	O	O
Three-phase motors 7 kW (9,5 hp) 50 Hz with direct start		O	O	O	O
Single-phase motors 2,2 kW (3 hp) 50 Hz		O	O	O	O
Single-phase motors S1 3,6 kW (4,8 hp) 60 Hz		O	O	O	O
Exhaust outlets diameter	mm	120	120	120	120

- A with wagon 1600 mm
 - B with wagon 2250 mm
 - C with wagon 2600 mm
 - D with wagon 3200 mm
 - E with 900 mm cutting width*
 - F with 1270 mm cutting width*
- *at the parallel fence*

elite
main
optional
devices

tablet holder on the
sliding carriage
Compatible with tablets from 8" to 11".



angular cutting device with flip-over stops
To rapidly perform mitre cuts without moving the squaring fence.
Recommended for mitre cuts on small work pieces.

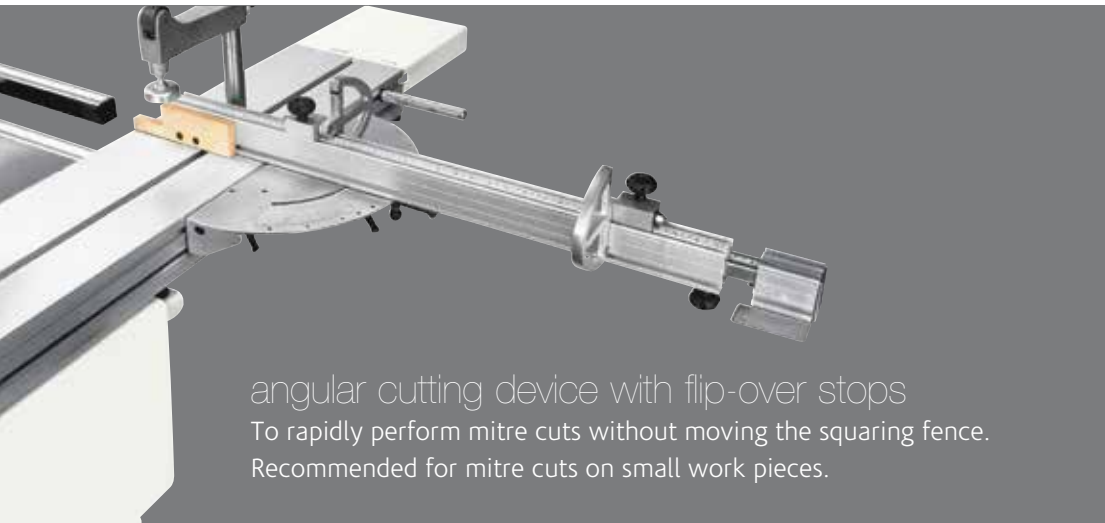

overhead blade protection
For totally safe machining.



pre-set angular
cutting device
directly positioned
on squaring frame
To find rapidly the most
common angles with the
squaring fence. Useful for
large work pieces.



digital readout for the fence
position on the parallel fence
It allows precise positioning with the
magnetic strip sensor.



"Tersa" cutter block

Automatic knives clamping by means of the centrifugal force ensures safe and precise machining. The system, without fixing screws, makes knives substitution extremely fast.



cast iron mortiser

Drilling holes and mortises are easily carried out. Complete with exhaust hood, 120 mm diameter and 16 mm chuck.



"Xylent" spiralknife cutter block with 3 series of knives

The 3 spiralknives give an exceptional finish. Reduced noise during machining provides a more comfortable working environment. It also improves the dust extraction due to the production of very small chips. Each cutter has 4 tips which can be rotated into the cutting position when worn. Therefore increasing the production life of the cutter block before knives require replacement.

self-centering chuck
0-16 mm "Wescott" type
The mortiser spindles can be rapidly substituted without the necessity of adjustment.



maintenance case for "Xylent" spiralknife

Complete with:

- 1 cleaning/degreasing liquid bottle for the resins cleaning
- 1 set dynamometric key
- 2 bit Torx
- 10 inserts
- 5 screws
- 1 brass bristle brush to clean the spindle with mounted in inserts
- 1 steel bristle brush to clean the inserts housings



chuck with clamp

It allows harder machining thanks to the stronger bits. The chuck includes 3 clamps 5/10/16 mm.



additional overturning fence for thin work pieces
It ensures optimum operator safety when machining thin work pieces.



A



B

interchangeable spindle (A)
For a very quick spindle substitution. Among the spare spindle, it is available also the spindle for router bits. (B)

tenoning table and protection hood
For the tenoning operations on the spindle moulder. It consists of:

- table
- protection hood for tools, 275 mm diameter
- exhaust hood, 120 mm diameter



Dado set
Mechanical presetting to use a tool (not included) in place of the main blade.



electric pre-setting and flip over support for feeder
This solution allows a total exclusion of the device and prevents interference with other parts of the machine.



additional table on the sliding carriage
For the support of large dimensioned panels.

minimax si 315es

elite main optional devices

S Standard
O Option

	cu 410e	fs 41e	st 4e	sc 4e
"SCM Thundercut" Optimizer/Sequencer App	S	-	S	S
Tablet holder on the sliding carriage	O	-	O	O
Angular cutting device with flip-over stops	O	-	O	O
Pre-set angular cutting device directly positioned on squaring frame	O	-	O	O
Digital readout for the fence position on the parallel fence	-	-	O	O
Additional table on the sliding carriage	O	-	O	O
Overhead blade protection	-	-	O	O
Numerical readouts for the groups positioning	O	O	O	O
"Tersa" cutter block	O	O	-	-
"Xylent" spiralknife cutter block with 3 series of knife	O	O	-	-
Maintenance case for "Xylent" spiralknives	O	O	-	-
Cast iron mortiser	O	O	-	-
Self-centering chuck 0-16 mm "Wescott" type	O	O	-	-
Chuck with clamp	O	O	-	-
Additional overturning fence for thin work pieces	-	O	-	-
Three movement adjustable spindle moulder fence	O	-	O	-
Tenoning table and protection hood	O	-	O	-
Electric pre-setting and flip over support for feeder	O	-	O	-
Interchangeable spindle	O	-	O	-
Wheels for machine movement	O	O	-	-
Dado set	-	-	O	O

PROMPT AND EXPERT TECHNICAL SUPPORT THROUGH A NETWORK OF 1000 TECHNICIANS AND AN INVENTORY OF 36,000 SPARE PARTS.

HIGHLY SPECIALISED TECHNICIANS, EFFICIENT
MANAGEMENT AND 6 SPARE PARTS BRANCHES
AROUND THE WORLD GUARANTEE A CLOSE,
SAFE AND EFFECTIVE TECHNICAL SUPPORT.

SERVICE

SCM provides a service that goes beyond the purchase, to guarantee the long term performance of your technological production system and peace of mind for your business.

A COMPLETE RANGE OF AFTER-SALES SERVICES

- installation and start-up of machines, cells, lines and systems
- tailored training programs
- telephone support to reduce times and costs when machines are not working
- preventive maintenance programs to guarantee long term performance
- complete renovation of machines and plants to renew the added value of the investments
- custom upgrading to update machines and plants and meet new production requirements



SPARE PARTS

SCM Group can count on 140 spare parts professionals worldwide to meet any request with real time shipments.



36,000 SPARE PARTS

Our spare parts inventory, with a value of 12 million euros, covers every single machine



SPARE PARTS GUARANTEED

We guarantee also hard to find parts, with 3,5 million euros invested in "critical" spare parts.



IMMEDIATE AVAILABILITY

Over 90% of orders received are carried out the same day thanks to the huge inventory available.



6 BRANCHES AROUND THE WORLD

The spare parts service can count on worldwide support (Rimini, Singapore, Shenzhen, Moscow, Atlanta, São Bento do Sul)



500 SHIPMENTS A DAY



THE STRONGEST WOOD TECHNOLOGIES ARE IN OUR DNA

SCM. A HERITAGE OF SKILLS IN A UNIQUE BRAND

Over 65 years of success gives SCM the centre stage in woodworking technology. This heritage results from bringing together the best know-how in machining and systems for wood-based manufacturing. SCM is present all over the world, brought to you by the widest distribution network in the industry.

65+ years history

3 main production sites in Italy

300.000 square metres of production space

20.000 machines manufactured per year

90% export

20 foreign branches

400 agents and dealers

500 support technicians

500 registered patents



In SCM's DNA also strength and solidity of a great Group. The SCM Group is a world leader, manufacturing industrial equipment and components for machining the widest range of materials.

SCM GROUP, A HIGHLY SKILLED TEAM EXPERT IN INDUSTRIAL MACHINES AND COMPONENTS

INDUSTRIAL MACHINERY

Stand-alone machines, integrated systems and services dedicated to processing a wide range of materials.



WOODWORKING TECHNOLOGIES



TECHNOLOGIES FOR PROCESSING COMPOSITE MATERIALS, ALUMINIUM, PLASTIC, GLASS, STONE, METAL

INDUSTRIAL COMPONENTS

Technological components for the Group's machines and systems, for those of third-parties and the machinery industry.



SPINDLES AND TECHNOLOGICAL COMPONENTS



ELECTRIC PANELS



METALWORK



CAST IRON



Company of the Scm Group

registered office:

via Emilia, 77
47921 Rimini, Italia
T. +39 0541 700111
F. +39 0541 700232

sales office:

via Casale, 450
47826 Villa Verucchio, Rimini, Italia
T. +39 0541 674111
F. +39 0541 674274
scm@scmgroup.com
www.scmwood.com

Scm Industria Spa

Professional Workshop Machinery

via Valdicella, 7
47892 Gualdicciolo,
Repubblica di San Marino
scm@scmgroup.com

sales dept. Italy:

T. +378 0549 876911
F. +378 0549 999604

foreign sales dept.:

T. +39 0541 674111
F. +39 0541 674274
www.scmwood.com

The motors powers in this catalogue are expressed in S6, except where otherwise specified. In this catalogue, machines are shown in CE configuration and with options. We reserve the right to modify technical specifications without prior notice, provided that such modifications do not affect safety as per CE norms.

rev.01
03/2021

Mic Studio





SCM GROUP SPA

via Casale 450 - 47826 Villa Verucchio, Rimini - Italy
tel. +39 0541 674111 - fax +39 0541 674274
scm@scmgroup.com
www.scmwood.com



00L0593163D